

ECO 15 Cod. **00841283**
ECO 15/L Cod. **00845660**
TAV. 401- 3

Luglio 2010

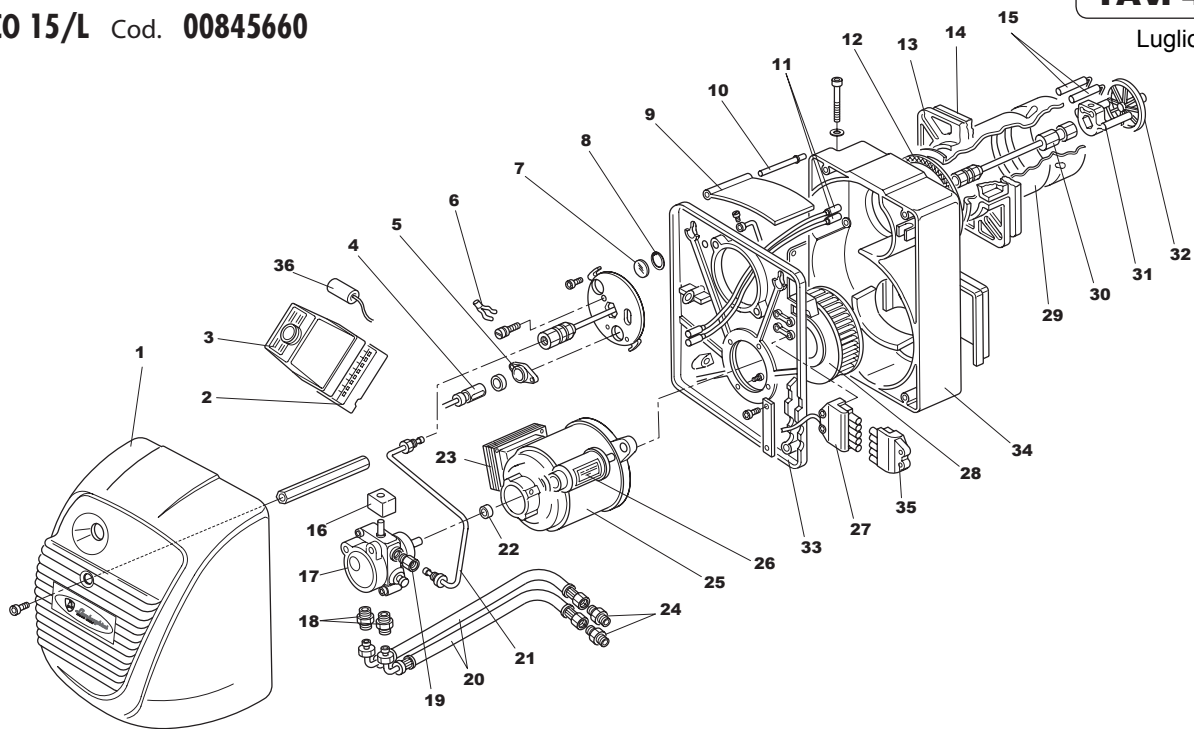

Pos.	Cod.	Denominazione	Denomination	Denomination	Denominación
1	1.13775.0	Cofano	Cover	Capot	Tapa
2	4.04206.0	App.Landis LMO 14	Control box	Coffret de sécurité	Programador
3	4.01551.0	Zoccolo	Base	Base	Base
4	4.03644.0	Fotoresistenza	Photocell	Photorésistance cellule	Fotoresistencia
5	4.03642.0	Supporto fotoresistenza	Photoresistor holder	Support photorésistance	Suporte fotoresistencia
6	1.11865.0	Molla raccordo mandata	Delivery coupling spring	Ressort du raccord départ	Muelle racor ida
7	1.11871.0	Vetrino ispezione	Inspection window	Viseur de flamme	Mirilla de inspección
8	3.00135.0	Anello seeger	Seeger	Seeger	Seeger
9	1.11893.0	Bandella aria	Air flap	Clapet d' air	Palomilla
10	1.12283.0	Perno bandella	Air flap shaft	Arbre clapet air	Arbol palomilla aire
11	1.13760.0	Cavo elettrodo accensione	Electrode cable	Cable èlectrode	Cable electrodo
12	1.11887.0	Guarnizione boccaglio	Draught tube gasket	Guelard joint	junta boca de fuego
13	1.11880.0	Flangia attacco caldaia	Boiler connect. flange	Flange connex. chaudière	Brida de fijación a la caldera
14	1.11881.0	Guarnizione isolante	Insulating gasket	Joint isolant	Junta aislante
15	4.04031.0	Elettrodi	Electrodes	Electrodes	Electrodos
16	4.01870.0	Bobina SUNTEC	Coil	Bobine	Bobine
	4.03473.0	Bobina DANFOSS	Coil	Bobine	Bobine
17	4.03648.0	Pompa SUNTEC	Pump	Pompe	Bomba
	4.04193.0	Pompa DANFOSS	Pump	Pompe	Bomba
18	1.05802.0	Niplo 1/4"	Pump coupling 1/4"	Raccord pompe 1/4"	Racor bomba 1/4"
19	1.11875.0	Raccordo tubo mandata	Delivery tube coupling	Raccord conduit de départ	Racor tubo ida
20	1.06922.0	Flessibile	Hose	Flexible	Flexible
21	1.11894.0	Tubo mandata	Feeding tube	Ligne alimentation	Tubo alimentacion
22	4.03646.0	Giunto motore (ACC)	Joint motor (ACC)	Joint du moteur (ACC)	Junta motor (ACC)
	4.04183.0	Giunto motore (SIMEL)	Joint motor (SIMEL)	Joint du moteur (SIMEL)	Junta motor (SIMEL)
23	4.04416.0	Trasformatore	Transformer	Transformateur	Transformador
24	1.00119.0	Niplo 3/8"	Flex coupling 3/8"	Raccord flexible 3/8"	Racor flexible 3/8"
25	1.11895.0	Motore 185 W (ACC)	Motor (ACC)	Moteur (ACC)	Motor (ACC)
	1.13686.0	Motore 185 W (SIMEL)	Motor (SIMEL)	Moteur (SIMEL)	Motor (SIMEL)
26	4.04231.0	Condensatore (ACC)	Condensor (ACC)	Condensateur (ACC)	Condensador (ACC)
	4.04186.0	Condensatore (SIMEL)	Condensor (SIMEL)	Condensateur (SIMEL)	Condensador (SIMEL)
27	4.03422.0	Presca	Socket	Prise	Toma
28	4.03713.0	Ventola	Fan	Ventilateur	Turbina
29	1.11898.0	Boccaglio	Draught tube	Guelard	Boca de fuego
	1.11914.0	Boccaglio (ECO 15/L)	Draught tube (ECO 15/L)	Guelard (ECO 15/L)	Boca de fuego (ECO 15/L)
30	1.11897.0	Supporto gicleur	Nozzle holder	Support gicleur	Linea inyector
	1.11915.0	Supporto gicleur (ECO 15/L)	Nozzle holder (ECO 15/L)	Support gicleur (ECO 15/L)	Linea inyector (ECO 15/L)
31	1.11876.0	Supporto elettrodi	Electrodes holder	Support électrodes	Soporte electrodos
32	1.11888.0	Disco deflettore	Deflector	Deflector	Deflector
33	1.12049.0	Piastra componenti	Components' plate	Plaque composantes	Placa componentes
34	1.12286.0	Corpo bruciatore	Burner body	Corps du brûleur	Cuerpo quemador
35	4.03210.0	Spina	Plug	Fiche	Enchufe
36	4.04116.0	Filtro antidisturbo	Antijamming filter	Filtre antiparasite	Filtro antiparasitario